

Edgecombe County

PLANNING & INSPECTIONS

Planning: (252) 641-7803
Inspections: (252) 641-7802

E-911 Addressing: (252) 641-4802
Fax: (252) 641-6913



REQUIREMENTS FOR MOBILE HOMES

MOBILE HOME IDENTIFICATION: (Must be posted before you can occupy home)!

MOBILE HOMES OR MODULAR HOMES SHALL HAVE **PHYSICAL ADDRESS OR MAILING ADDRESS DISPLAYED ON THE HOME AND/OR MAILBOX.** YOU MAY USE 4" STICK-ON NUMBERS OR EQUIVALENT.

TO OBTAIN ADDRESS, CALL 252-641-4802, APPROXIMATELY 5 TO 7 DAYS FROM TODAY.

MOBILE HOME OR MODULAR HOME SET UP:

MOBILE HOMES MAY BE SET-UP BY THE **LICENSED DEALER, OR SET-UP CONTRACTOR.** THE HOMEOWNER MAY SET-UP HIS HOME, BY FIRST SIGNING A WAIVER FORM STATING THAT HE WILL ACT AS HIS OWN CONTRACTOR.

MODULAR HOMES MAY BE SET-UP BY A LICENSED GENERAL CONTRACTOR, OR BY THE DEALER, **ONLY** IF THE DEALER HAS OBTAINED A \$5,000 SURETY BOND. THE "**HOMEOWNER MANUAL**" SHOULD BE PRESENT AT THE TIME OF INSPECTION.

PLUMBING REQUIREMENTS:

CHECK VALVE AND VACUUM BREAKER ON WATER LINE. WATER LINE FROM WELL, WITH WELL AND PUMP IN PLACE. WELL ELECTRICAL SUPPLY UNDERGROUND (**WATER PROOF**) WIRE AND BOTH WATER LINE AND WIRE TO BE MINIMUM OF 12" DEEP.

IF CONNECTING TO THE COUNTY WATER SYSTEM, CALL 252-823-5571.

SEPTIC TANK CONNECTION LEFT UNCOVERED (**DITCH FROM HOME TO TANK**) CONNECTION TO SEPTIC TANK SHALL BE CEMENTED. SEWER LINE (**IF APPLICABLE IN YOUR AREA**) LEFT OPEN AND CLEAN-OUT PLUG EVERY 50 FEET.

ELECTRICAL REQUIREMENTS:

1. ELECTRICAL WORK MUST MEET THE NATIONAL ELECTRICAL CODE.
2. CALL YOUR POWER COMPANY, MAKE APPLICATION AND ABOUT PLACEMENT OF POLE AND UNDERGROUND SERVICES **AS SOON AS POSSIBLE!**
3. LICENSED ELECTRICIANS ONLY, UNLESS YOU ARE THE HOMEOWNER.

4. YOU ARE RESPONSIBLE FOR WIRING FROM METER TO HOME.
5. METERBASES CAN BE MOUNTED DIRECTLY TO THE MOBILE HOME PROVIDING YOU OWN THE LAND. CENTER OF METER TO BE 5 FT. HIGH, OVERHEAD SERVICE MAST TO BE MINIMUM OF 12 FEET HIGH.
6. METERBASE POLES MUST BE 30 FEET OR LESS FROM THE MOBILE HOME.
7. CONDUIT **SHALL** EXTEND IN THE GROUND AT LEAST 18 INCHES AT METERBASE AND UNDERHOME OR IT CAN BE TOTALLY ENCLOSED IN CONDUIT AND ATTACHED UNDERHOME.
8. UNDERGROUND WIRE OR METAL MASTS ARE **OK** IF THEY MEET THE NEC REQUIREMENTS.
9. **ALL WIRE** BURIED TO HOME FROM METER MUST BE 24 INCHES DEEP.
10. BONDING STRAPS MUST BE IN PLACE ON ALL DOUBLE WIDE MOBILE HOMES.
11. **ALL WIRE** BURIED TO WATER PUMPS MUST BE 12 INCHES DEEP.

DECKS, STOOPS AND PORCHES & STEPS:

1. SHALL BE CONSTRUCTED ACCORDING TO THE NORTH CAROLINA REGULATIONS FOR MANUFACTURED HOMES 2004 EDITION. **SEE ATTACHED PICTURE.**

3.11.4 Landings

A minimum 3' X 3' landing shall be required at the top of all exterior stairs where any egress door (not screen or storm door) swings outward over the stairs. Landings that are thirty-six (36) square feet or less in area may be constructed according to the provisions of this Code. All such landings, whether at the top or bottom of the stairs, which are greater than thirty-six (36) square feet in area are considered to be "decks" and shall be constructed in accordance with the North Carolina Residential Code (current Edition).

INSPECTIONS REQUIRED:

1. FOOTING INSPECTION, IF REQUIRED BY MFG. BEFORE CONCRETE CAN BE POURED.
2. INSULATION INSPECTION IN MARRIAGE WALLS IF HOME IS A DOUBLEWIDE.
3. BLOCKING, TIE DOWNS, PLUMBING TEST, SEWER AND ELECTRICAL INSPECTION BEFORE SKIRTING IS INSTALLED.
4. SKIRTING, AND STEPS AT EVERY OUTSIDE DOOR FOR CERTIFICATE OF OCCUPANCY.

NOTE: SINGLEWIDE HOMES REQUIRE ONLY ONE INSPECTION. COMPLETE ALL WORK INCLUDING SKIRTING THE FRONT AND THE BACK OF THE HOME. LEAVE THE SKIRTING OFF THE ENDS OF THE HOME.

PLEASE NOTE: THESE REQUIREMENTS ARE MANDATORY BY THE N.C. DEPT. OF INSURANCE, BEFORE ANY ELECTRICITY CAN BE CONNECTED. THERE WILL BE A \$40.00 CHARGE FOR ADDITIONAL TRIPS MADE FOR INSPECTIONS. (To be determined by the building inspector)

PLEASE CALL THIS OFFICE (641-7802) 24 HOURS IN ADVANCE TO SCHEDULE INSPECTIONS, WHEN ALL THE ABOVE WORK HAS BEEN COMPLETED. IF NO ONE CAN BE PRESENT DURING INSPECTION, PLEASE LEAVE THE REAR DOOR UNLOCKED AND WE WILL LOCK IT AFTER THE INSPECTION. **NO APPOINTMENTS WILL BE GIVEN BY THE INSPECTIONS DEPARTMENT, DUE TO THE SIZE OF THE COUNTY AND THE NUMBER OF INSPECTORS IN OUR STAFF.**

- REMEMBER:**
1. PLANNING DEPT. ISSUES APPROVAL FOR LOT (252-641-7802)
 2. TAX COLLECTIONS DEPT. ISSUES MOVING PERMIT (252-641-7810)
 3. INSPECTIONS DEPT. ISSUES PERMIT TO SET-UP THE M.H. ON A LOT (641-7802).
PERMITS ARE ISSUED BETWEEN 8 AM AND 4 PM MONDAY-FRIDAY.
 4. HEALTH DEPT. ISSUES WELL & SEPTIC TANK PERMITS (252-641-7573)
 5. TAX ASSESSOR'S DEPT ISSUES TAX VERIFICATION FORM (641-7856)

INSPECTORS ARE USUALLY IN THE OFFICE EACH MORNING FROM 8:00 A.M. – 9:00 A.M. IF YOU HAVE QUESTIONS. (252-641-7802)

UNDERPINNING/SKITRING:

ELECTRICAL SERVICE **WILL NOT** BE ASSIGNED TO ANY MANUFACTURED HOME UNTIL THE SKIRTING/UNDERPINNING HAS BEEN INSTALLED AND ADDRESS POSTED.

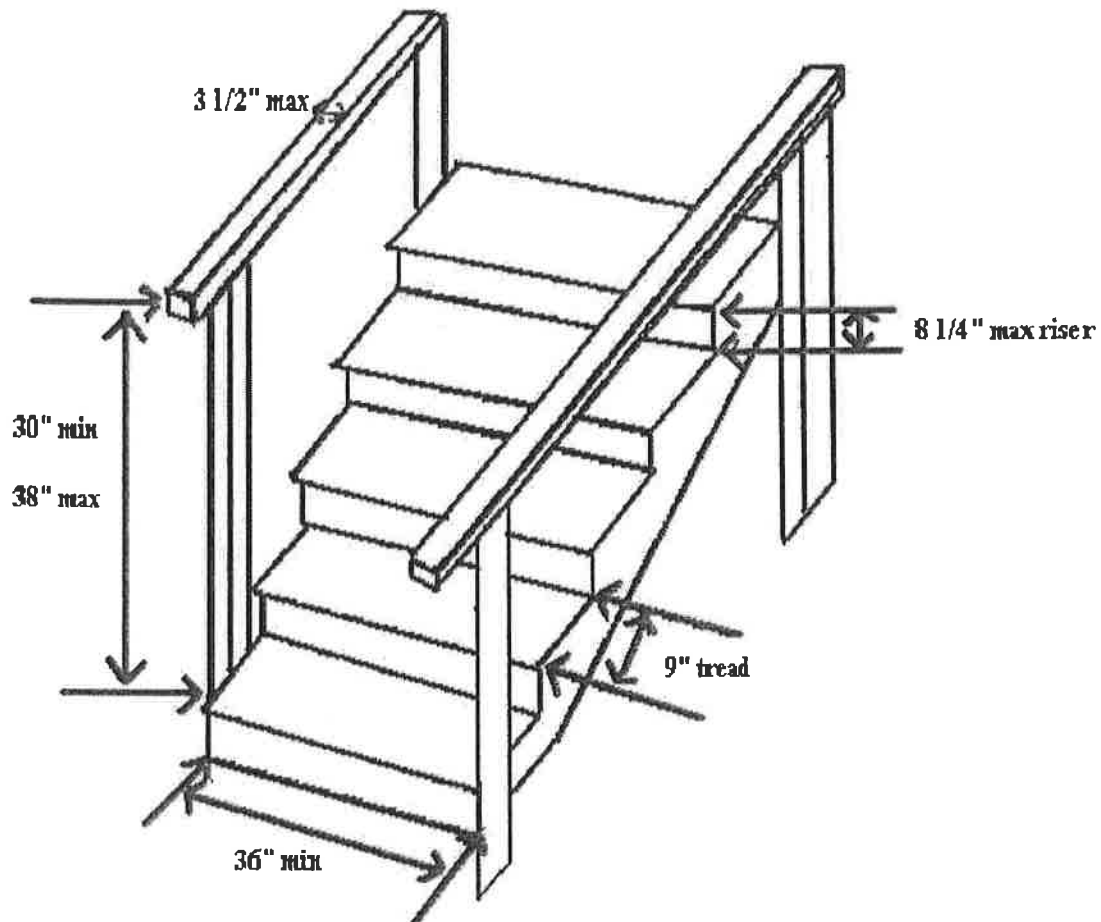

1. TO BE BUILT WITH TREAD LUMBER ONLY
2. OVER THREE (3) STEPS HIGH REQUIRES HAND RAIL ON BOTH SIDES
3. TREADS TO BE 9 INCH MINIMUM
4. RISER TO BE 8 ¼ INCHES MAXIMUM
5. HANDRAIL TO BE 30 – 38 INCHES HIGH
6. THE STEP WIDTH SHOULD BE A MINIMUM OF 36 INCHES WIDE
7. TWO (2) HANDRAILS, 36 INCHES ABOVE TOP OF STEPS

Edgecombe County

Planning: (252) 641-7803
Inspections: (252) 641-7802



PLANNING & INSPECTIONS

Email address:
permit@co.edgecombe.nc.us

Information Needed for Mobile Home Permits

- ✓ **Zoning Certificate:** The Edgecombe County Planning Department (Room 205) will provide a zoning for all property not located in any Town Limits or ETJ, with the exception of Leggett and Speed. If you are moving to a town or will be in a town's ETJ, please obtain the zoning from that jurisdiction prior to applying for permits.
- ✓ **Septic Report or Improvements Permit:** The Environmental Health Department (Room 443) must give approval of all septic systems prior to any permits being issued. A copy of the septic system report is required before a mobile home permit is issued. If public sewer is used, this document will not be needed.
- ✓ **Bill of Sale or Title:** This document verifies ownership of the mobile home.
- ✓ **Tax Assessor's Certification:** This document must be signed off on by the Edgecombe County Tax Assessor's (Room 312) and Tax Collector's (Room 154) offices. Tax Departments may request title of home.
- ✓ **Moving Permit:** If the home is being moved, a moving permit must be obtained before a mobile home permit is issued.
- ✓ **Set up Contractor Form:** This document must be filled out and signed by the set up contractor or the dealership.

Please present all of the applicable documents with your permit application to the Edgecombe County Planning & Inspections Department. Permits are issued between 8:00 a.m. and 4:00 p.m., Monday - Friday in Room 205. Payment is accepted by cash, check, money order, credit card or debit card. No over the phone credit card or debit card payments will be accepted.

EDGECOMBE COUNTY PLANNING & INSPECTIONS

P.O. BOX 10, 201 St. Andrew Street

Tarboro, NC 27886

Phone: 252-641-7802 Email: permit@co.edgecombe.nc.us

Manufactured Home Building Permit Application

Application Date: _____	Tax Parcel ID#: _____		
Applicant: _____	Phone #: _____		
Homeowner (as shown on title/bill of sale): _____	Phone #: _____		
Address: _____	City: _____	State: _____	Zip: _____
Person to live in Home: _____	Phone #: _____		
Land Owner's Name: _____	Phone #: _____		
Value of Home: _____	Size of Home: _____	Year of Home: _____	
Power Company: _____	Premise or Account #: _____		
Dealer/Sales Co. & License #: _____	Phone #: _____		
Address: _____			
Set-up Contractor & License #: _____	Phone #: _____		
Address: _____			
Electrician & License #: _____	Phone #: _____		
Address: _____			
A/C Installer & License #: _____	Phone #: _____		
Address: _____			
Plumber & License #: _____	Phone #: _____		
Address: _____			

Underpinning? Brick <input type="checkbox"/> Vinyl <input type="checkbox"/> Well <input type="checkbox"/> County Water <input type="checkbox"/> Has driveway been installed on property? Yes <input type="checkbox"/> No <input type="checkbox"/>	Permit Fees: Singlewide \$110.00 Doublewide \$150.00 Triplewide \$175.00
---------------------------------------------------------------------------------------------------------------------------------------------------------------------------------------------------------------------------------------------------------	--------------------------------------------------------------------------------

*I hereby certify that all information in this application is correct and will comply with the State Building Code and all other applicable State and local laws, ordinances and regulations. **Work may only begin after approval and issuance of the permit.** Failure to obtain a manufactured home permit will result in a Stop work Order and a \$100 contractor fine/ \$50 homeowner fine will be assessed. Zoning Certificate may need to be purchased from the Town if the home is Inside of a Town's Jurisdiction. Re-inspection fees are charged at \$40 per trip.*

Printed Name of Applicant/ Agent

Signature of Applicant/Agent

Date

Information for Set-up Contractor or Dealership

Requirement for Edgecombe County Manufactured Home Building Permit Application

Contractor's Name & License #: _____ Phone #: _____

Contractor's Address: _____ City: _____ State: _____ Zip: _____

I propose to set-up a properly labeled manufactured home at the following address:

Address: _____ City: _____ State: _____ Zip: _____

I am a North Carolina licensed manufactured home set-up contractor.

License #: _____ Name of Business: _____

Printed Name of Set-up Contractor

Signature of Set-up Contractor

Date

I am the owner of the proposed manufactured home. It is my intention to personally set-up the proposed manufactured home, and I understand that problems which may arise due to set-up of the home will be solely my responsibility, and I will be left with no recourse through the State or local jurisdiction and must assume total liability for correction of any problems the occur as a result of the set-up of the manufactured home. I personally have a thorough knowledge of the requirements of the **CURRENT** State of North Carolina Regulations for Manufactured Homes that require me to set-up the home in accordance with the home manufacture's installation manual for **NEW** manufactured homes and either the home manufacture's installation instructions or the **CURRENT** State of North Carolina Regulations for Manufactured Homes for **USED** manufactured homes with regard to the set-up of my home.

Printed Name of Owner

Signature of Owner

Date

NOTE: **ONLY** the **CURRENT** manufactured home manufacturer's installation instructions may be used for the installation of a **NEW** manufactured home. If the homeowner is acting as his or hers own set-up contractor as prescribed in Section 1.2.4 of the **CURRENT** State of North Carolina Regulations for Manufactured Homes and in all cases the license name and number of the set-up contractor shall appear on the permit.

EDGECOMBE COUNTY ASSESSOR'S OFFICE
201 SAINT ANDREW ST., SUITE 312, TARBORO, NC 27886

MANUFACTURED HOME TAX CERTIFICATION APPLICATION

New owner name: _____

New owner mailing address: _____

New location address: _____ Lot Number _____

Is the home located in a Mobile Home Park? Yes No If YES, list the name of the mobile home park: _____

Parcel ID: _____

Land owner's name if different than homeowner: _____

Listing for Tax year(s): _____ Purchase date: _____ Cost: _____ Year: _____

Make: _____ Model: _____ Width: _____ Length: _____ VIN# _____

Home purchased from a dealer? Yes No

Home purchased from a Financial Institution as: Repossessed Used home

Home purchased from individual? Yes No If YES, give name and address of prior owner: _____
address: _____

Home will be: Rental Occupied by Owner Held for Inventory

If home purchased from individual or financial institution (excluding homes from dealer lot), please answer the following:

Address of the home at time of purchase if different from address above. Street _____

City: _____ State: _____ County: _____

Was the home moved to the current location before or after purchase? _____ Before _____ After _____

Was a MOBILE HOME MOVING PERMIT obtained by you to move the home? _____ Yes No

If NO, please list the name of person to whom the MOVING PERMIT was issued: _____

MOBILE HOME MOVERS Name and Address: _____

Have ALL taxes for the current year and prior years been paid? Yes No

If NO, all prior years taxes must be paid before certification will be issued.

Years owed _____ Amount owed _____ Acct # _____

Has the title been updated with DMV? Yes No

Name shown on title: _____

This form must be completed, signed, dated, and returned to the Edgecombe County Tax Assessor's Office. Information not completed or any discrepancies in the information provided will delay the processing time for completing the Manufactured Home Certification form. **If you are relocating the home you must provide the Edgecombe County Planning Office with a Mobile Home Moving permit.**

Affirmation of homeowner: GS 105-310.-311. Under penalties prescribed by law, I hereby affirm that to the best of my knowledge and belief this listing, including any accompanying statements, is true and complete. Social Security Number: The disclosure of this number is voluntary. This is needed to establish the identification of individuals. The authority to require this number for the Administration of a tax is given by United States Code Title 42, Section 405©(2)©(i).

Taxpayer Signature _____ Date _____

Employer: _____ Phone: Work: _____ Home: _____

Social Security No. _____

FAILURE TO SUBMIT THIS FORM WILL DELAY PERMITS

EDGECOMBE COUNTY ASSESSOR'S OFFICE
201 SAINT ANDREW ST., SUITE 312, TARBORO, NC 27886
MANUFACTURED HOME TAX CERTIFICATION

TAX ASSESSOR'S OFFICE RM 312

**EDGECOMBE COUNTY ASSESSOR'S OFFICE CERTIFIES THAT THE
MANUFACTURED HOME LISTED ABOVE IS PROPERLY LISTED/REGISTERED
WITH OUR OFFICE.**

Certified by: _____ Date: _____

TAX COLLECTOR'S OFFICE RM 154

**EDGECOMBE COUNTY TAX COLLECTIONS OFFICE CERTIFIES ON THE
MANUFACTURED HOME LISTED ABOVE:**

THERE ARE NO TAXES DUE TO EDGECOMBE COUNTY.

ALL EDGECOMBE COUNTY PROPERTY TAXES HAVE BEEN PAID.

Certified by: _____ Date: _____